

Development of Arduino-based high heat detector temperature control prototype for household appliances

Rhoda Mae L. Casinillo, Allecia Leona A. So, Maezel V. Mandaya, Sonny Adrian J. Dabalos,
Mark Ceasar S. Enriquez, Jas Felicisimo A. Cane

Science Technology, Engineering, and Mathematics Program, Senior High School Department, Liceo de Cagayan University,
Cagayan de Oro City, Philippines

Article Info

Article history:

Received Dec 4, 2023

Revised Feb 28, 2024

Accepted Apr 21, 2024

Keywords:

Arduino

Electric fan

High heat detector

LM35 sensor

Temperature control

ABSTRACT

In the Philippines, fires are a widespread concern, with plenty of incidents attributed to electrical appliances. These incidents are a leading cause of non-open flame fires in the country, highlighting the urgent need for preventative measures. Existing devices could only trigger an alarm at 100 °C without shutting off the appliance automatically. To address these limitations, the researchers aimed to develop a high heat detector with 95% detection accuracy and less than 5% error in detecting high heat. This device used an Arduino Uno Board and relay to trigger an automated power-off mechanism in appliances experiencing high heat. Temperature changes were detected, and alarms were activated using an LM35 temperature sensor and buzzer. The accuracy of the LM35 sensor was assessed through hot bath tests, which included 12 trials at each temperature level between 80 °C and 150 °C with 10 °C intervals. The prototype's performance revealed an average error rate of 1.13% and an average standard deviation of 0.9403. The computed F1 Score of 98% indicated that the prototype fulfilled the objectives. Functionality tests confirmed that the prototype successfully achieved its intended goal by shutting off the appliance when the threshold temperature was reached and enabling its operation otherwise.

This is an open access article under the [CC BY-SA](#) license.



Corresponding Author:

Jas Felicisimo A. Cane

Senior High School Department, Liceo de Cagayan University

Rodolfo N. Pelaez Blvd., Kauswagan, 9000 Cagayan de Oro City, Philippines

Email: jASFelicis.cane@g.msuiit.edu.ph

1. INTRODUCTION

In recent years, fire incidents have been prevalent across the region of the Philippines. Between 2018 and 2021, 1,734 fire incidents were started by electrical appliances [1]. It is regarded as the second most frequent source of fire that is not brought on by open flames in the Philippines. Focusing on urban fires in [2], the country loses a significant amount each year due to fire catastrophes, as the overall number of fire casualties reported in 2018 was 326, with 14,364 documented cases of fire incidents, which grew to 16,408 from January to October 2019. Numerous people have died in electrical fire incidents brought on by the malfunction, failure, or deterioration of electrical equipment, and significant property damage has also been incurred [3]. More residual current flows through outdated or damaged appliances as their insulation deteriorates, eventually resulting in insulation burning due to excessive heat produced. Short circuits may also occur, which is to blame for most electrical appliance-related accidents.

Since the widespread use of electrical appliances has permeated the electrical distribution system in recent years, there has been an increase in the number of electrical fires. People have learned to adapt and have settled into a new modality for work and school environments due to the coronavirus disease (COVID-19)

pandemic, wherein the usage of household appliances has been consistently practiced, becoming a part of their daily lives, and working for more extended periods than usual [4]. Most rural household fires are accidental in nature [5]. "Electricity" continues to be one of the leading causes of these fires. Factors such as illegal connections, improper wiring practices (such as octopus wiring), faulty electrical systems, electric short circuits, and overloading contribute to household fires. Additionally, fires caused by the usage of home appliances are often linked to electrical issues. Overheating of appliances can lead to electrical socket explosions, which can ultimately result in electrical fires. Similarly, the use of low-quality appliances can also contribute to these hazardous situations. Electric fans, ceiling fans, and electric water heaters are by far the most highly subjected household appliances regarding electrical fires [6]. The potential of overheated machinery poses a significant risk to the security of the house. However, people commonly underestimate the cost of neglecting household equipment maintenance and fail to understand the danger of highly heated machinery. The American Society for Testing and Materials International [7] explained that the temperature of an appliance is dependent on its rating; for an appliance to be considered overheating, it must have a temperature value of 100 °C. This rating is already beyond 60 °C, the temperature that a human hand can handle.

Other studies have already developed devices that detect overheating. An example of this is a device created by Microtronics Technologies [8] in 2014. The temperature sensor detects a temperature reaching an overheating state and sends an output to the comparator to the model 89s51 microcontroller. The device, however, used a resistance temperature detector (RTD) - a sensor whose resistance changes with temperature as it relies on the change in resistance in the temperature-sensing material as an indicator of thermal activity. However, this sensor only has an upper threshold of 100 °C and does not automatically turn off the appliance. Based on the studies mentioned above, the researchers decided to develop a preventive device that allows early detection of potential high heating and has an automated system that powers down the appliance to prevent accidents like fire on frequently used household appliances.

The alarming increase in electrical fires in the Philippines sheds light on the associated risks, casualties, and property damage. These electrical fires have resulted in casualties, significant property damage, and even fatalities. The issue is exacerbated by factors such as the widespread use of electrical appliances, improper wiring practices, overheating, and the increasing reliance on household appliances due to the COVID-19 pandemic. To address this issue, the researchers attempted to develop a high heat detector temperature control prototype that shuts down a household appliance once the control temperature reaches its threshold level using an Arduino Uno Board and a relay. The development of this prototype aimed to help prevent and lessen fires, leading to the prevention of millions worth of properties and life losses.

2. LITERATURE REVIEW

This section examines key ideas of prototype development and electronics engineering that serve as the foundation for this study. Moreover, it explores prior literature and studies that have utilized the aforementioned concepts. The following studies serve as the academic foundations for the development of the research.

2.1. High heating of electronic components

Almubarak [9] emphasizes that electronic components generate heat during operation, and while designed to withstand specific heat levels, various factors can lead to excessive heat, risking damage to the components. Material degradation is a common consequence, altering physical and chemical properties and affecting performance. Incidents of fires caused by lighting appliances have been documented, indicating potential hazards. Akitsu and Mitani [10] demonstrated that overheating of incandescent light bulbs, deterioration of fluorescent lamp fixtures with mercury, and fires caused by electrical stabilizers and conventional fluorescent light fixtures with LED bulbs are all potential fire hazards. Liao *et al.* [11] focuses on the increasing risk of overheating in consumer electronics, particularly portable devices like laptops and smartphones, as miniaturization demands lead to compact designs with reduced thermal flow. The study demonstrates this phenomenon using a semiconductor, revealing that densely packed transistors in a small area hinder heat dissipation. In the Philippines, electrical appliances are identified as the second leading cause of fires, with faulty appliances causing over 1,700 fires between 2018 and 2021 [1]. Occeno [6] highlights electrical post failures, short circuits, and overheating as top causes of electrical fires in homes, with varying frequencies across provinces. Overheating is a significant concern, particularly in Antique, where it accounts for 33% of fires. These findings suggest a substantial risk of fires due to overheated electrical appliances, emphasizing the need for a high-temperature detector prototype to monitor household devices and prevent incidents, reducing property damage and casualties from electrical fires. To develop this system, it is necessary to have a thorough understanding of various concepts that were used to design and implement the prototype. The microcontroller used in the prototype was Arduino, and knowledge of sensors was essential to making the system functional. Readings done on the topic of the electrical relay were crucial

in developing the proposed auto-off mechanism of the said prototype. Also, reviewing previous studies in this field helped identify the unique features of the prototype and fill any gaps in the research.

2.2. Arduino Uno

Hussain *et al.* [12] define a microcontroller as a single-circuit computer with a central processing unit (CPU), random access memory (RAM), read-only memory (ROM), and input/output (I/O) ports. Arduino, a popular platform for microcontroller-based projects, is known for its open-source nature and user-friendly features. The Arduino microcontroller incorporates communication and input/output ports for connecting peripheral devices, processing information received from these devices [13]. Louis [14] emphasizes Arduino's hardware, known as the Arduino Board, which houses the main microcontroller and pins for connecting sensors and actuators. The accompanying software, Arduino IDE, simplifies C or C++ programming for the Arduino Board, enabling the execution of programs, known as sketches. This study focuses on the Arduino Uno board, a variant of the Arduino series, chosen for its industry reputation, widespread use in developmental studies, and compatibility with the LM35 sensor. The Arduino Uno board's user-friendly features and compatibility with the LM35 sensor make it an ideal choice for developmental studies. Liu *et al.* [15] utilized the LM35 sensor for accurate soil temperature measurements, demonstrating correction coefficient values of no more than one. Similarly, Junizan *et al.* [16] employed the LM35 temperature sensor to effectively control a fan's speed based on surrounding temperature, indicating the sensor's successful application in temperature-based control systems.

2.3. LM35 temperature sensor

A sensor is a device that recognizes and reacts to specific inputs from the physical environment, including light, heat, motion, moisture, pressure, and other phenomena [17]. Serving a critical role on the internet of things (IoT), sensors facilitate data collection and processing in various environments, connecting the physical world to the logical world. The LM35 temperature sensor is designed for precise temperature measurement, providing accurate outputs proportional to the temperature in °C [18]. With low self-heating and an operating temperature range from -55 °C to 150 °C, the LM35 offers improved accuracy compared to thermistors and easy interfacing with readout or control circuitry. Ayeni [19] emphasizes the dynamic role of temperature sensors in diverse applications, ranging from manufacturing drugs to preventing reliability issues in electronic systems. A reliable temperature detection circuit is crucial for quality control and preventive measures against overheating risks. The proposed device model in the paper enables temperature detection, displaying measured temperatures on an LCD with corresponding warnings and using an RGB indicator to represent different system conditions. Ramos [20] conducted a study on LM35 sensors for measuring internal concrete temperature during curing processes. Large volumes of concrete can experience internal heat buildup, affecting structure stability. LM35 sensors, embedded in concrete, proved accurate, durable, and cost-effective for monitoring internal heat during curing, making them suitable for precise readings in prototype development processes.

2.4. JQC-3FF-S-Z relay

In the realm of electrical engineering, a relay is defined as a device with contacts that open and close a switch in response to an input signal, enabling external control of a circuit [21]. Gurevich [22] further emphasizes its role as a switch for input signals, acting as an interpreter to control devices based on external inputs. This study focuses on electrical relays, which facilitate the control of electrical output devices through electrical inputs, a fundamental component in various appliances. Simatupang *et al.* [23] addressed voltage fluctuations using relays, showcasing an Arduino-based safety system prototype. The system protects household devices from voltage issues by employing the relay's switching capabilities. The prototype utilizes a DC power source and protection device, downscales AC power to DC voltage for Arduino signaling, and employs a relay to shut off the load during abnormal circumstances. While effective in simulating AC source fluctuations, the prototype lacks a battery, limiting its ability to safeguard against events like blackouts effectively. Considering all these studies mentioned, the development of the project involved using an Arduino Uno to operate the relay of an appliance to automatically turn off an electric fan when its motor hits the high heating threshold. The prototype device's input was provided by an LM35 temperature sensor, and the output was handled by a JQC-3FF-S-Z relay, which is the main distinction. The JQC-3FF-S-Z relay is a 5V power relay that can route AC power in response to a low-level signal. The Arduino Uno gadget, which turns off the electric fan by cutting off the power source to it, produced a low-level signal.

2.5. Temperature-controlled appliances

The electric fan, a common appliance in Filipino households for cooling, is deemed a sensible and cost-effective means, particularly during hot summer months [24]. Despite widespread use, the design of

electric fans often overlooks essential features, such as motion and temperature sensors, leading to inefficient use, safety risks, and energy wastage, as observed in lecture halls at Bulacan State University (BuLSU). To address this, the researchers developed a motion activated, temperature-controlled electric fan, aiming to create intelligent products that reduce electricity consumption while being environmentally friendly. Prototypes underwent a two-week simulation and dry run, evaluating parameters like operation time, fan speed control turn-on times, and motion sensitivity. The study's results indicate that the design met expectations, offering a valuable and adaptable configuration for its intended purpose. Intelligent ventilation systems, exemplified by this project, provide a practical solution for controlling hot and humid environments. Jahlool [25] created a design and simulation of an automatic temperature control and alert system based on the PIC16F887 microcontroller. The system aimed to control multiple appliances based on temperature readings from the LM35 sensor, reducing human intervention and increasing reliability. The system included ventilation, cooling, heating, and alert functions, improving working conditions in industries, warehouses, and laboratories. The microcontroller PIC16F887 acted as the central control unit, and the 16x2 LCD showed the operational status of the system. Drivers, relays, and LED indicators were also used to indicate the working appliances. The system was implemented and simulated using Proteus professional software v8.0 and mikroC PRO for PIC version 6.6.1 software to write the program and generate the hex file for system operation.

Paglinawan *et al.* [4] aimed to create a tool to detect and prevent electrical problems in frequently used household appliances. The device helps prevent overheating of wires and overloading, which can reduce the risk of accidents in the home. The device also has a system to monitor current and voltage levels, as well as measure the temperature of the wire. Results from the study showed that the device had a 93.76% accuracy in measuring current, 99.18% accuracy in measuring voltage, and 98.16% accuracy in measuring wire temperature. It was also noted that the maximum wire temperature was between 40° to 60°, with anything above that potentially causing damage to the wire. A correlation was also found between the current being used and the temperature of the wire.

2.6. Overheat detectors

Singh *et al.* [26] aimed to create an automated overheat detector for machines, utilizing an 8051 series microcontroller and a thermistor. While successful in detecting machine temperatures, the device had a limited maximum temperature detection of 100 °C due to the thermistor's characteristics. Chin *et al.* [27] developed an automatic temperature-sensing fan using Arduino Uno and an LM35 temperature sensor. The fan adjusted its speed based on temperature readings to prevent heat strokes. This study demonstrated the feasibility of automatically reading appliance temperatures with the proper setup of electronics, showcasing the potential of Arduino Uno and LM35 sensors. Ayeni [19] proposed a temperature monitoring device that provides real-time feedback, displaying temperature readings on an LCD and including a warning message indicating the system's status. The study incorporated an RGB light changing color to represent the temperature status. Zhou and Schoepf [28] reviewed overheating detection methods for faulty connections in circuits, identifying the risks of arc flashes and fires. They designed a low-cost, portable device using an LM35 temperature sensor to address limitations in existing technologies. Lin & Lin [29] created an overheat prevention device for a projection apparatus, detecting the angle of the heating source and adjusting the cooling module's operation. While limited to projection apparatuses, this study aims to extend its application to various appliances and provide user warnings. Inspired by Carvajal *et al.* [30], a similar study developed an overheat detector with an automated system using an Arduino Uno Board and a relay. However, it lacked an LCD for temperature display, warning messages, and LED lights for indicating different temperature conditions.

Therefore, the research improved upon previous findings by updating various electronics and methods used in the study. A developed ODET sensor [30] was utilized as the main standard or framework of the device as this study used a resembling process for developing and testing the Arduino-based high heat detector temperature control prototype. The LM35 sensor used in the study is a variation of the LM35c sensor that was used in the temperature-sensing fan by Chin *et al.* [27] which is more accurate and consistent in its temperature readings and can withstand higher temperatures. The Arduino Uno's ATmega328P microcontroller can provide more computing power and features. The prototype also followed Ayeni's [19] model by employing an LCD to show the measured temperature and LED lights to show the different conditions of household appliances by changing color as temperature changes. Lin and Lin's [29] concept of cooling the machine was applied to household appliances by shutting them off with a relay module. This study also enhanced the automated machine checker by Singh *et al.*, [26] and adapted it to the appliances by using an Arduino Uno board and LM35 sensor to support a wider temperature range than a thermistor. The combination of electronics in this study has also been considered by researchers to be cost-effective for prototype development.

2.7. Related legal bases

Republic Act No. 9514: An Act Establishing a Comprehensive Fire Code of the Philippines, Repealing Presidential Decree No. 1185 and for Other Purposes Section II [31] states that “It is the policy of the State to ensure public safety, promote economic development through the prevention and suppression of all kinds of destructive fires.” Thus, the development of a high heat detector will prevent fires caused by appliances from starting, especially at home and in the workplace.

Supplement 10 to World Health Organization (WHO) Technical Report Series [32] was used in the implementation of the data gathering, specifically for the hot bath tests. This report assisted the study in ensuring the accuracy and credibility of the device, which is crucial in realizing the Philippine government’s goal of ensuring public safety and promoting economic growth by reducing costs associated with lives and property losses. Using the hot bath tests, as specified in the WHO report, helped guarantee the validity of the results and increase the confidence in the prototype.

3. METHOD

The research design used in this study was a developmental research design, which aimed to develop a high heat detector prototype for household appliances. To be precise, this study followed the modified research and development (R&D) method developed by Sugiyono [33]. The testing focused on determining the device’s accuracy based on parameters, percentage error, and F1-Score, as discussed in the prototype specification section.

3.1. Research procedure

Since this research was directed at developing an Arduino-based prototype, the research method used in this paper was the modified R&D method [33]. The method involves the creation of a product and testing its effectiveness. The procedure of this study is observed in Figure 1.

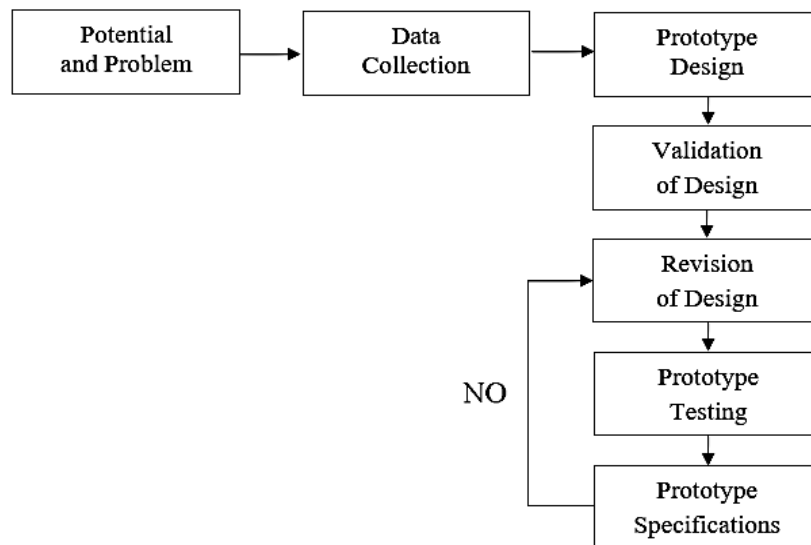

Figure 1. The procedure of the modified R&D [33]

This study mainly focused on developing an Arduino-based high heat detector to monitor the temperature of a household appliance and power it down when it reaches a high heat temperature using Arduino Uno Board, Arduino IDE, JQC-3FF-S-Z relay, LEDs, and resistors. As proof of concept, the researchers focused on a specific appliance: an electric fan. The researchers designed a wiring diagram that uses the electricity supplied to the electric fan and has a relay module as shown in Figure 2. The LM35 sensor was exposed to the main motor of the electric fan to detect temperature changes. Once the electric fan experienced high heat levels, the prototype would emit a sound using an LM35 sensor and a Piezoelectric Buzzer, serving as an alert mechanism. Users were then informed to manually deactivate the alarm by pressing a designated button. The prototype boasted a 95% accuracy rate in detecting temperature changes and notifying users accordingly. Furthermore, the LED incorporated in the design displayed temperature

information by changing colors based on the measured heat intensity of the device. The LED would exhibit different colors to indicate varying temperature conditions: green for temperatures below or equal to the normal range (95 °C), orange for temperatures between the normal range and the threshold value (above 95 °C but below 100 °C), and red accompanied by a buzzing alert when the temperature reached or exceeded the threshold level (100 °C or above).

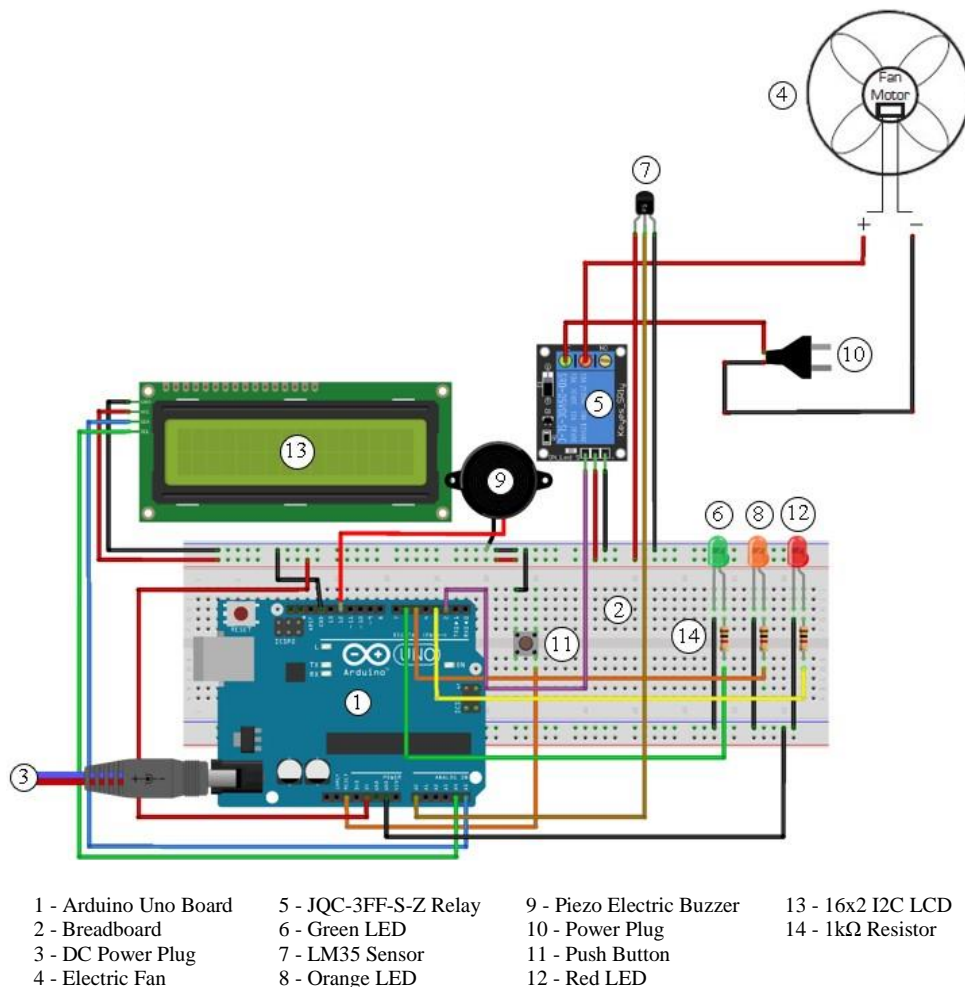

Figure 2. Diagram of the Arduino-based high heat detector temperature control prototype

The functionality described above was made possible by utilizing the various connections of the relay, specifically the Normally Closed (NC) and Normally Open (NO) socket pins of the JQC-3FF-S-Z relay. The NC configuration indicated that the relay was initially in a closed-circuit state, allowing the current to flow until a signal was received to open the circuit. On the other hand, the NO configuration meant that the relay was in an open-circuit state and did not permit current to pass until a signal was received. In this system, the NC socket pin was employed to keep the electric fan operational until a signal was triggered by high heat conditions. The Arduino microcontroller was directly connected to the relay to transmit signals, with the COM pin serving as the common connection for the appliance. This arrangement enabled the implementation of an automatic shut-off mechanism by utilizing the NC socket, allowing the electrical appliance to be turned off once a signal was sent from the Arduino. The device remained powered by being directly connected to the socket wire, even after the relay cut off the power supply from the appliance.

3.2. Schematic diagram of the prototype

The researchers designed a wiring diagram that uses the electricity supplied to the electric fan and has a relay module as depicted in Figure 3. This was used to develop the prototype for testing. When the device detects high heating, it sends a signal to the relay module, which turns off the electric fan.

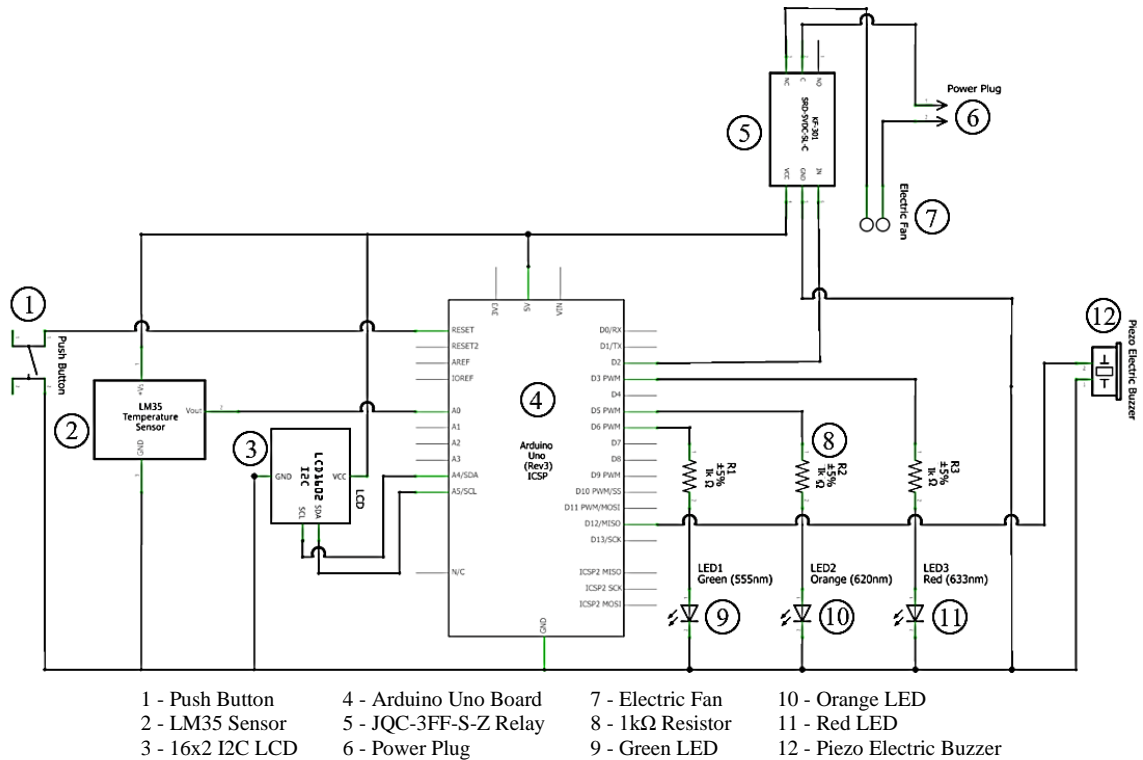

Figure 3. Schematic diagram of the prototype with relay

3.3. Statistical tools

3.3.1. Percent error formula

To establish an accurate approach for comparing experimental results with a predefined target value, a precise method was employed to calculate the disparity between the exact value and the average outcome obtained from the hot bath test. This analysis involved conducting 12 trials at each temperature level. To determine the deviation, the percent error was utilized, employing (1).

$$\delta = \left| \frac{v_a - v_e}{v_e} \right| \times 100\% \quad (1)$$

with δ being the percent error, v_a being the actual value observed or the average outcome of the trials per temperature, and v_e being the expected value [34].

3.3.2. Confusion matrix

To test a classification model or system, the confusion matrix was used [35]. This shows the data in a two-dimensional matrix presenting the number of actual data that followed the expected outcome and data that did not. This matrix presents data in a two-dimensional format, illustrating the number of actual data instances that corresponded to the expected outcome and those that did not. A Confusion has four components, namely: true positive (T_P), false positive (F_P), true negative (T_N), and false negative (F_N). true positive represents the number of instances correctly classified as positive, indicating the successful detection of the target threshold level. False positive represents the number of instances mistakenly classified as positive when they should have been negative. True negative denotes the number of instances correctly classified as negative, demonstrating accurate identification of the absence of the target threshold level. Lastly, false negative represents the number of instances incorrectly classified as negative when they should have been positive. By utilizing the confusion matrix, these components offer valuable insights into the performance of a classification model or system, aiding in the evaluation and refinement of its effectiveness in correctly identifying and classifying different outcomes.

3.3.3. Precision

The precision of the device's output, which measures the consistency or reliability of the device in correctly identifying positive instances, can be computed using the formula derived from the confusion

matrix. This formula assesses the proportion of correctly classified positive instances out of all the instances predicted as positive by the device. By utilizing the confusion matrix and computing precision, it becomes possible to evaluate the consistency and accuracy of the device's output, allowing for a more comprehensive assessment of its performance in correctly identifying positive instances and minimizing false positive predictions. This can be computed using (2).

$$Precision = T_p / (T_p + F_p) \quad (2)$$

3.3.4. Recall

The recall, also known as sensitivity or true positive rate, assesses the ability of the prototype to accurately recognize true positive instances. It can be computed using the formula derived from the confusion matrix. This formula quantifies the proportion of correctly classified positive instances out of all the actual positive instances in the dataset. By utilizing the confusion matrix and computing recall, the performance of the prototype in accurately detecting and recognizing true positive instances can be assessed. It offers valuable information on the prototype's sensitivity in identifying positive cases, contributing to a comprehensive evaluation of its performance in correctly recognizing positive instances and minimizing false negatives. This can be computed using (3).

$$Recall = T_p / (T_p + F_n) \quad (3)$$

3.3.5. Specificity

The specificity of the prototype, which measures its ability to accurately identify true negatives, can be computed using the formula derived from the confusion matrix. This formula assesses the proportion of correctly classified negative instances out of all the actual negative instances in the dataset. By utilizing the confusion matrix and computing specificity, it becomes possible to evaluate the prototype's accuracy in correctly recognizing true negative instances and minimizing false positive predictions. The specificity metric is crucial in assessing the prototype's performance in distinguishing and accurately classifying negative cases, contributing to a comprehensive evaluation of its overall effectiveness in correctly identifying both positive and negative instances. This can be computed using (4).

$$Specificity = T_n / (T_n + F_p) \quad (4)$$

3.3.6. F1-Score

The F1-Score, a widely used metric for evaluating the accuracy of a prototype in detecting high-heat incidents, can be computed using the formula derived from the confusion matrix. The F1-Score combines precision and recall providing a comprehensive measure of the prototype's overall performance. By utilizing the confusion matrix and computing the F1-Score, the accuracy of the prototype in detecting high-heat incidents can be assessed in a single metric. The F1-Score provides a balanced evaluation, considering both the precision and recall values and enabling a comprehensive assessment of the prototype's performance in accurately detecting high-heat incidents. This can be computed using (5).

$$F_1 \text{ Score} = 2 \times (Precision \times Recall) / (Precision + Recall) \quad (5)$$

3.3.7. Prototype evaluation form

The evaluation of the design objectives intended functions, product quality, ergonomics, reliability, durability, and portability of the prototype was conducted using the evaluation form from the Faculty of Mechanical Engineering at Universiti Teknologi MARA (UiTM). This evaluation form served as a comprehensive tool to assess various aspects of the prototype's performance and characteristics. By utilizing this evaluation form, the researchers were able to systematically evaluate whether the design objectives were met, if the intended functions were effectively fulfilled, the overall quality and reliability of the product, the ergonomic considerations in its design, and the durability and portability of the prototype. The use of the evaluation form provided a structured and standardized approach to comprehensively assess the prototype's performance and determine if it met the desired criteria and requirements across multiple dimensions, facilitating a thorough evaluation of the prototype's overall effectiveness.

3.4. Arduino IDE coding

The prototype utilizes an Arduino code programmed in C/C++ that controls the temperature monitoring and activation of a fan based on the temperature readings obtained from a temperature sensor, as depicted in Figure 4. The programming follows two main functions: the setup function, executed once to set project definitions, and the loop function, which runs continuously, constituting the core of the program. The

code incorporates crucial libraries like *"LiquidCrystal_I2C"* and the tone library for LCD and buzzer functionalities, respectively. It establishes parameters for high and normal temperature thresholds, defining pins for the LM35 temperature sensor, LEDs, and buzzer within the setup function. The LCD is initialized for temperature display, and serial communication is initiated. This code effectively controls temperature monitoring and fan activation based on temperature sensor readings, ensuring the maintenance of safe temperature levels in the prototype.

```

sketch_may22a.ino  sketch_may22a.ino  27
1  const int high = 100; //set high parameter 28  void loop() {
2  const int normal = 95; //set normal parameter 29
3  30  vout=analogRead(sensor);
4  #include<LiquidCrystal_I2C.h> 31  int rawvoltage= analogRead(A0);
5  const int sensor=A0; 32  float millivolts= (rawvoltage/1024.0) * 5000;
6  float temp; 33  float fahrenheit= millivolts/10;
7  float vout; 34  float celsius= (fahrenheit - 32) * 0.556;
8  #define GREEN 6 35
9  #define ORANGE 5 36
10 #define RED 3 37  lcd.clear();
11 #define BUZZER 12 38  lcd.setCursor(2,0); //Start writing on 0.0 on lcd screen
12 39  lcd.print("Temp ");
13  LiquidCrystal_I2C lcd(0x27 ,16, 2); 40  lcd.setCursor(7,0);
14 41  lcd.print(celsius); //Temperature value
15 42  lcd.print((char)223);
16  void setup() { 43  lcd.print("C"); //Celsius
17  pinMode(A0, INPUT); //sensor 44
18  pinMode(ORANGE, OUTPUT); //blue 45  if (temp <= normal) { //cold
19  pinMode(GREEN, OUTPUT); //green 46  digitalWrite(2,LOW);
20  pinMode(RED, OUTPUT); //red 47  digitalWrite(GREEN, HIGH);
21 48  digitalWrite(ORANGE, LOW);
22  pinMode(sensor,INPUT); 49  digitalWrite(RED, LOW);
23  pinMode(2,OUTPUT); 50  lcd.setCursor(5,1);
24  Serial.begin(9600); 51  lcd.print("FAN ON");
25  lcd.init(); 52
26  lcd.backlight(); 53
27  }
54  else if (temp >= high) { //high
55  digitalWrite(2,HIGH);
56  digitalWrite(GREEN, LOW);
57  digitalWrite(ORANGE, LOW);
58  digitalWrite(RED, HIGH);
59  tone(BUZZER, 350);
60  lcd.setCursor(5,1);
61  lcd.print("FAN OFF");
62  }
63
64  else { //fine
65  digitalWrite(2,LOW);
66  digitalWrite(GREEN, LOW);
67  digitalWrite(ORANGE, HIGH);
68  digitalWrite(RED, LOW);
69  lcd.setCursor(5,1);
70  lcd.print("FAN ON");
71  }
72
73  delay(2000);
74  }

```

Figure 4. Arduino IDE coding

In the loop function, the code converts the analog reading from the temperature sensor into Celsius, displaying it on the LCD screen after clearing. The fan activation or deactivation is determined based on the temperature reading, utilizing the relay's auto-off feature. LED indicators and LCD messages adjust to represent the current temperature status. If the temperature surpasses the 100 °C threshold, the red LED and buzzer alert the user. A 2-second delay serves to enhance user readability and stabilize the system after operations, ensuring accurate and reliable temperature measurements. This delay contributes to improved user experience, system stability, and measurement accuracy in the temperature monitoring prototype.

4. RESULTS AND DISCUSSION

This section presents the data gathered from the employed research procedure. Raw data obtained for all threshold levels are shown in the tables. The tabulation and interpretation of the results and statistical analysis are also discussed in this chapter. The steps to develop an Arduino-based high heat detector temperature control prototype shall be as follows.

4.1. Prototype development and designing

4.1.1. Potential and problem

The first step in the procedure of the modified R&D method was to conduct preliminary research to identify the potential and problem addressed in this study. This process entailed gathering information from literature and journals, identifying scientific issues, examining evidence from similar research, searching for relevant scholarly literature using Google Scholar, reviewing primary materials and procedures for prototype development, developing expertise and skills related to the research problem, establishing objectives for each stage, and planning research steps. The dataset sourced from the Philippine Statistics Authority, utilizing information provided by the Bureau of Fire Protection, reveals that between the years 2018 and 2021, a total of 1,734 fire incidents were attributed to electrical appliances [1]. The cause is shown in Table 1. It is regarded as the second most prevalent source of fire that is not caused by open flames in the Philippines. This preliminary analysis provided a foundation and became the basis for the prototype development.

4.1.2. Data collection

This step involved collecting data from various sources related to the identified potential and problem. Based on the data collected from the preliminary analysis, the researchers found the need to develop

an Arduino-based prototype that can detect a high heat temperature in commonly used household appliances and power them down once high heat is detected. With the development of this prototype, the study aimed to contribute to the agenda of the Philippine government of ensuring public safety and economic growth by potentially saving millions in costs related to both lives and property while also testing the credibility of the device using appropriate methods. Therefore, this study improved upon previous findings in the ODET sensor developed by Carvajal *et al.* [30] the temperature-sensing fan by Chin *et al.* [27], model by Ayeni [19], concept of machine cooling by Lin and Lin [29], and the automated machine checker by Singh *et al.* [26], by updating various electronics and methods used in the study.

Table 1. Causes of fire incidents in the Philippines [1]

Causes of fire incidents	2018	2019	2020	2021
Total	16,675	18,612	14,420	12,850
Electrical connections	5,319	3,104	3,812	2,743
Unattended open flame:				
Torch or <i>sulo</i>	858	114	110	79
Neglected cooking or stove	877	949	931	737
Candle or <i>gasera</i>	521	369	414	285
Cigarette butt	1,128	1,096	936	628
Matchstick or lighter	439	447	287	165
Direct flame contact or static electricity	69	2,399	2,082	1,079
Electrical appliances	432	438	483	381

4.1.3. Prototype design

The prototype development, as shown in Figure 5, involved incorporating advancements from previous studies, particularly utilizing the ODET sensor [30] as the primary framework. Key improvements included a more accurate LM35 sensor variant, adopted from Chin *et al.*'s [27] temperature-sensing fan, showcasing enhanced temperature readings and increased heat tolerance. The Arduino Uno with ATmega328P microcontroller offered heightened computing capabilities. Ayeni's [19] model influenced the incorporation of an LCD for temperature display and LED lights signaling appliance conditions. The cooling concept by Lin and Lin [29] was adapted for household appliances using a relay module. The automated machine checker by Singh *et al.* [26] was enhanced for household appliances by integrating Arduino Uno and LM35 sensor, extending the temperature range beyond a thermistor. This combination of electronics was deemed cost-effective for prototype development. Electrical components were assembled based on a wiring diagram, and the prototype casing, constructed from a transparent acrylic sheet material, featured a T-like shape with a length of 26 cm, a width of 18 cm, a height of 8.5 cm, and holes for components.

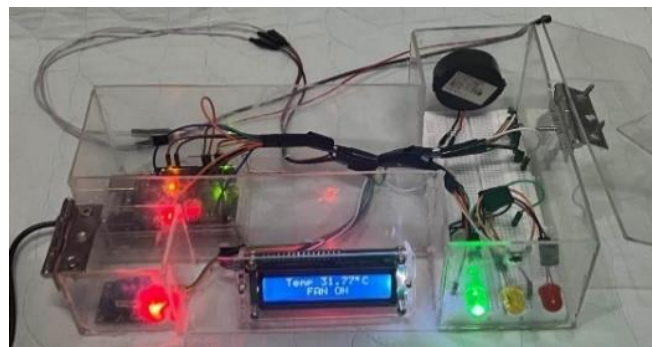

Figure 5. Construction of prototype

4.1.4. Validation of design

This stage involved assessing the practicality and effectiveness of the designed prototype in performing its intended functions. To evaluate the prototype, an expert in the field used an evaluation form that included the pertinent research tests, analyses, and reliability assessments performed during the study. The evaluation form adapted from the Faculty of Mechanical Engineering at the Universiti Teknologi MARA (UiTM) included the performance, functionality, quality, manufacturing aspects, maintainability, health safety and risk issues, innovation and commercialization, and aesthetical values. On March 20, 2023, the

prototype was evaluated by a software engineer specializing in coding, specifically the Arduino IDE coding used in this study. The coding languages used in developing the prototype were inspected and verified to ensure its proper functionality and assess if the objectives, product quality, ergonomics, reliability, durability, and portability of the prototype were met.

4.1.5. Revision of design

Based on the evaluation results, comments, and feedback from the expert during the validation of the design, the prototype was revised and improved by addressing the weaknesses identified in the previous step as in Figure 6. Specifically, the expert suggested making the temperature readings more stable and making the prototype portable. Based on these suggestions, the researchers revised and improved the prototype design by covering the pins of the LM35 with heat shrink and a silicone sealant and making a portable prototype casing in which the wirings are enclosed and not visible. Using a reusable code that can handle different device thresholds was also suggested. For possible future advancements, the expert suggested implementing an SMS or mobile notification feature in the prototype for a more accessible and faster high-heat notification system. Overall, the revision focused on fixing issues that hindered the proper functioning of the prototype.



Figure 6. Revised prototype design

4.2. Prototype testing

4.2.1. First hot bath test

The prototype underwent the first hot bath test, as seen in Figure 7. The pins of the LM35 sensor were covered with heat shrink and coated with silicone sealant to protect the gaps to prevent liquids from damaging them. The head of the sensor was liquid-resistant, so liquids did not damage it. The methods of the hot bath tests were based on a technical supplement to WHO Technical Report Series, No. 961, 2011 [32]. Oil temperatures ranging from 80 °C to 150 °C were used in 12 trials for each level during the first hot bath test. Temperature readings from both the prototype and a food thermometer were recorded in each trial. The prototype was programmed to trigger an alarm and flash a red LED light for the initial six trials at each temperature level. For the subsequent six trials, the prototype alerted at a temperature 5 °C below the designated level.

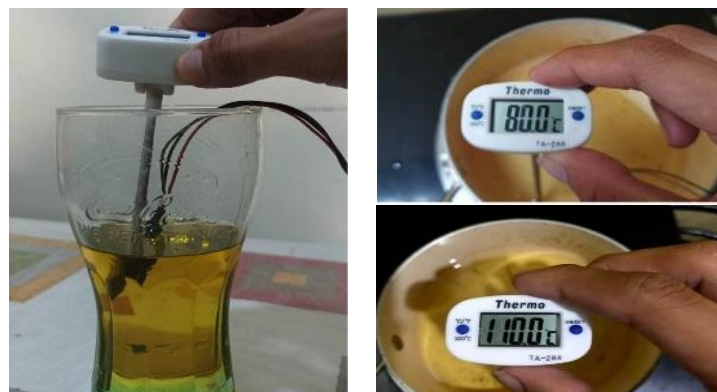

Figure 7. Set-up for the first hot bath test

4.2.2. First hot bath test results

Hot bath tests were performed on the prototype under real-world conditions, covering temperatures from 80 °C to 150 °C in 10 °C intervals, with 12 trials at each level. Mean and standard deviation were employed for result interpretation, with the evaluation encompassing percent error against expected values and F1-score calculations using the Confusion Matrix. The presented data in Table 2, categorized by temperature, elucidate the standard deviation (s) for each level, providing insights into the spread of recorded data points around the mean. The computed probabilities indicate confidence levels, with a 68% likelihood that temperature readings fall within mean $\pm 1s$, 95% within mean $\pm 2s$, and 99% within mean $\pm 3s$, signifying increased confidence and wider expected ranges of values. The study emphasizes the reliability and precision of temperature measurements, showcasing the accuracy and consistency of the recorded data. Given that the computed standard deviation was almost zero, the measured values and their average were compared relatively to ensure that the temperature readings of the prototype were sufficiently accurate to be relied upon.

Table 2. Mean value, standard deviation, and percent error of trials per temperature level in the first hot bath test

Temperature Level (°C)	Mean Value (°C)	Standard Deviation, s	Error (%)
80	79.20	0.7338	1.00
90	90.02	0.6077	0.02
100	100.18	0.5542	0.18
110	110.62	0.7306	0.56
120	119.36	0.7589	0.53
130	129.59	0.8612	0.32
140	138.47	1.389	1.09
150	146.71	2.161	2.19
Average		0.68	0.74

The prototype exhibits accurate temperature detection at both low and high threshold levels, achieving the objective of less than a 5% error of the mean. With mean values derived from 12 trials at each temperature level, the measured error ranges from 0.02% to 2.19%, averaging at 0.74%. In comparison to prior innovations, such a temperature-sensing fan [27] and automated machine checker [26], which had maximum threshold values of 100 °C and 70 °C, respectively, the developed device boasts a significantly expanded temperature range. This versatility enhances monitoring capabilities for precise temperature control and detection, particularly in appliances operating at higher temperatures, contributing to improved safety and reduced fire incidents in households. An analysis of the hot bath test, conducted in twelve trials across threshold levels, revealed initial false negatives followed by subsequent true positives, as shown in Table 3. To address this, a lower prototype threshold, considering an average error of 0.74%, was implemented, ensuring accurate detection of true positives with a 1.11 °C deviation at a given temperature level. The threshold level was adjusted to 5 °C below the actual high heating temperature for more reliable detection.

Table 3. Classification reading of trials per temperature level in the first hot bath test

Trial	Temperature Level (°C)							
	80	90	100	110	120	130	140	150
1	F _N	T _P	F _N	T _P	F _N	F _N	F _N	FN
2	F _N	T _P	T _P	F _N	F _N	T _P	F _N	FN
3	T _P	F _N	T _P	T _P	T _P	F _N	T _P	FN
4	F _N	T _P	F _N	F _N	F _N	F _N	F _N	FN
5	F _N	F _N	T _P	T _P	T _P	F _N	T _P	FN
6	F _N	F _N	F _N	T _P	F _N	T _P	F _N	FN
7	T _P	T _P	T _P	T _P	T _P	T _P	T _P	T _P
8	T _P	T _P	T _P	T _P	T _P	T _P	T _P	T _P
9	T _P	T _P	T _P	T _P	T _P	T _P	T _P	T _P
10	T _P	T _P	T _P	T _P	T _P	T _P	T _P	T _P
11	T _P	T _P	T _P	T _P	T _P	T _P	T _P	T _P
12	T _P	T _P	T _P	T _P	T _P	T _P	T _P	T _P

T_P - True Positive, T_N - True Negative, F_N - False Negative, F_P - False Positive

The evaluation of system or model performance involves different outcomes. A false negative occurs when the system incorrectly predicts a negative result, such as the failure of a high-heat detection prototype to identify high heat when it is present; conversely, a false positive happens when the system incorrectly predicts a positive result, indicating high heat when it did not occur [36]. True negatives are

achieved when the system accurately predicts the absence of high heat, and true positives occur when the system accurately predicts the presence of high heat [37], [38]. The study focused on analyzing experimental data trends, emphasizing the prototype's effectiveness in categorizing temperature readings and identifying high-heat situations, particularly through classification values. This approach enables the development of guidelines or alerts based on specific temperature ranges, offering a practical perspective on the prototype's performance in monitoring and detecting high-heat incidents.

The first and second six trials across all temperature levels yielded similar classification readings, reflected in consistent parameters as provided in Table 4. The prototype demonstrated perfect precision at 100%, minimizing the probability of false positives. Recall reached 0.68, indicating a 68% chance of detecting false negatives. However, no true negative readings were observed, indicating a lack of specificity—meaning the prototype did not detect high heat when it was absent. The prototype achieved an 80% accuracy in detecting high heating based on the F1-Score, falling short of the study's 95% accuracy objective. Consequently, the device's design was revised based on the first hot bath test results, prompting a second test to meet the required accuracy for the LM35 sensor.

Table 4. Classification reading of trials per temperature level in the first hot bath test

Temperature Level (°C)	Precision	Recall	Specificity	F1 Score
80	1.0	0.58	0	0.73
90	1.0	0.75	0	0.86
100	1.0	0.75	0	0.86
110	1.0	0.83	0	0.91
120	1.0	0.67	0	0.80
130	1.0	0.67	0	0.80
140	1.0	0.67	0	0.80
150	1.0	0.50	0	0.67
Average	1.0	0.68	0	0.80

4.2.3. Functionality test

In the functionality test, the prototype was connected to an electric fan to assess its performance under different temperature conditions as in Figure 8. Initially, with the threshold set to 100 °C, the electric fan activated at approximately 37.59 °C, indicating the operational functionality of the prototype. The green LED was illuminated as the temperature remained within the normal range. For a simulated high-heating scenario, the threshold was adjusted to 35 °C, and the relay cut off power to the electric fan at around 35.39 °C. The Red LED and buzzer were activated, signaling the auto-off mechanism. Subsequently, a repeat of the normal functionality test ensured the integrity of the electric fan's wiring after the high-heating simulation. An additional test involved gradually increasing the appliance's temperature from 36.23 °C to 45.19 °C after 5 minutes, surpassing the 40 °C threshold. The electric fan operated initially but was automatically turned off by the activated relay when the temperature reached 45.19 °C. The buzzer sounded, and the Red LED indicated the high-temperature condition. These functionality tests were repeated for consistency, affirming the prototype's ability to perform its designated functions effectively.

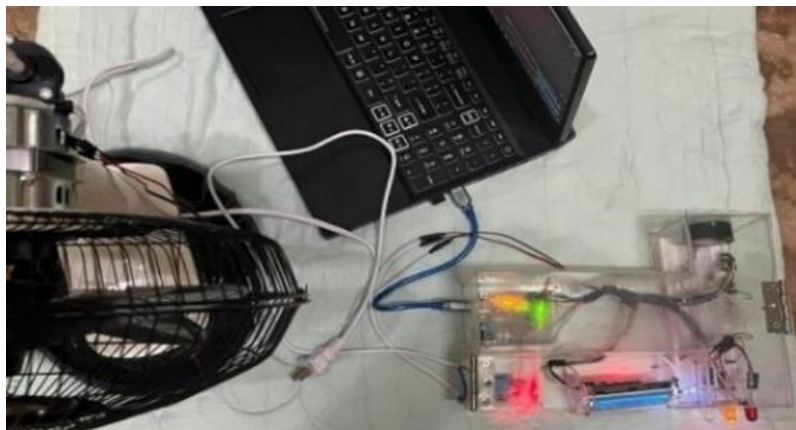

Figure 8. The prototype connected in parallel to the electric fan's wiring

4.2.4. Prototype specification

The prototype's specifications were thoroughly evaluated to ensure compliance with established standards and study objectives. In the first hot bath test, the prototype demonstrated an impressive percent error of 0.74%, meeting the stipulated objective of achieving less than a 5% error of the mean. This indicated the prototype's accurate temperature detection capability across both low and high threshold levels. However, in terms of the F1 score, the prototype's accuracy in detecting high heating was 80%, falling short of the desired 95% accuracy. Recognizing this gap, a second hot bath test was conducted to enhance the accuracy of the LM35 temperature sensor. The outcomes of the first hot bath test also prompted a design revision to address the accuracy requirements of the temperature sensor, showcasing the commitment to refining the prototype and meeting stringent detection accuracy criteria.

4.2.5. Revision of design

The prototype must have a 95% detection accuracy to support the primary objective of accurately detecting temperature changes in an appliance in terms of F1-Score. Following the needed accuracy detection of the prototype, the researchers conducted a second hot bath test to ensure that the above condition was met.

As a solution, a lower threshold value for the prototype was used to detect high heating. For instance, the temperature sensor had an average error of 0.74%. Thus, the temperature reading would mostly deviate by approximately 1.11 °C at a given temperature level, considering that the deviation can be calculated as the percent error divided by 100 and multiplied by the expected value of the temperature, which, in this case, is the temperature value of 150 °C. With this information, the researchers adjusted the threshold level to 5 °C lower than the appliance's actual high heating temperature level [30] to detect true positives accurately.

4.2.6. Second hot bath test

The first hot bath test is performed to assess the accuracy of the LM35 temperature sensor. However, the initial test did not yield the desired level of accuracy, as it had an 80% detection accuracy, as indicated by the F1 score. Subsequently, a second hot bath test was conducted, adjusting the temperature value to be 5 °C lower than the actual temperature. This adjustment resulted in a more accurate outcome. To meet the first objective of achieving a 95% detection accuracy for temperature changes in the appliance, the researchers carried out the second hot bath test, depicted in Figure 9. This evaluation allowed them to verify the reliability of the LM35 temperature sensor and ensure the required level of accuracy was attained. By comparing the measured temperatures with the known values of the hot bath test, the researchers could assess the reliability of the LM35 temperature sensor. The F1-Score calculations were then performed based on the comparison between the detected temperature changes and the actual changes in the hot bath. The F1-Score is a metric that combines precision and recall, providing an overall measure of detection accuracy.



Figure 9. Set-up for the second hot bath test

4.2.7. Second hot bath test results

The second hot bath test findings indicate a potential influence on the LM35 temperature sensor's readings when using a food thermometer with a ± 1 °C accuracy [39]. Despite this, the study affirms the LM35 temperature sensor's high reliability, maintaining confidence in its accuracy. The F1-Score analysis validates the sensor's precision at 98%, emphasizing its dependability for effectively monitoring and detecting temperature variations in the appliance. The average error, calculated from 12 trials at each temperature level, ranged from 0.31% to 2.72%, with an average error of 1.13%. This demonstrates the prototype's accurate temperature-detecting capabilities across low and high threshold levels, meeting the objective of less than a 5% mean error, which is shown in Table 5. The measurements surpassed the 100 °C limitation in previous developments, such as temperature-sensing fan [27] and automated machine checker [26].

Table 5. Mean value, standard deviation, and percent error of trials per temperature level in the second hot bath test

Temperature Level (°C)	Mean Value (°C)	Standard Deviation, <i>s</i>	Error (%)
80	79.75	0.5411	0.31
90	89.69	0.9306	0.34
100	99.14	0.7543	0.86
110	108.55	0.9464	1.32
120	118.97	1.035	0.86
130	128.34	1.264	1.28
140	138.08	0.9222	1.37
150	145.92	1.129	2.72
Average		0.9403	1.13

The prototype exhibited a notable increase in percent error at elevated temperatures, surpassing the 1.28% error threshold at 130 °C and maintaining elevated levels in the 140 to 150 °C range. This discrepancy is attributed to a potential voltage drop induced by other components in the device, given the LM35 sensor's output voltage's direct proportionality to centigrade temperature (10 mV/°C), as stated by Texas Instruments [40]. Possible reasons for this error include suboptimal functioning of the temperature sensor under stress or higher temperatures and undetected defective components in the electrical system. Despite these challenges, the prototype was deemed accurate enough for the study's objectives. The Second hot bath test consistently resulted in predominantly true positive outcomes for all threshold levels, highlighting the LM35 temperature sensor's consistent and reliable performance in accurately detecting temperature changes within the desired range, as shown in Table 6. However, in the 150 °C trial, three false negatives occurred, likely attributed to the suboptimal sensor performance under stress. Despite this limitation, the prototype successfully met the study's objectives and is considered sufficiently accurate.

Table 6. Classification reading of trials per temperature level in the second hot bath test

Trial	Temperature Level (°C)							
	80	90	100	110	120	130	140	150
1	T _P	T _P	T _P	T _P	T _P	T _P	T _P	T _P
2	T _P	T _P	T _P	T _P	T _P	T _P	T _P	T _P
3	T _P	T _P	T _P	T _P	T _P	T _P	T _P	T _P
4	T _P	T _P	T _P	T _P	T _P	T _P	T _P	F _N
5	T _P	T _P	T _P	T _P	T _P	T _P	T _P	T _P
6	T _P	T _P	T _P	T _P	T _P	T _P	T _P	T _P
7	T _P	T _P	T _P	T _P	T _P	T _P	T _P	F _N
8	T _P	T _P	T _P	T _P	T _P	T _P	T _P	T _P
9	T _P	T _P	T _P	T _P	T _P	T _P	T _P	T _P
10	T _P	T _P	T _P	T _P	T _P	T _P	T _P	F _N
11	T _P	T _P	T _P	T _P	T _P	T _P	T _P	T _P
12	T _P	T _P	T _P	T _P	T _P	T _P	T _P	T _P

T_P - True Positive, T_N - True Negative, F_N - False Negative, F_P - False Positive

As all the temperature levels showed consistent classification readings in the first and second six trials, it led to nearly identical results on parameters as shown in Table 7. The prototype achieved a perfect precision of 100%, indicating an extremely low probability of detecting a false positive. Contrastingly, its improved recall performance by 0.97 compared to the first hot bath test, implying that the probability of detecting a true positive was 97% in the prototype. However, there was no specific classification reading as the prototype did not detect high heat when high heat did not occur. Overall, the prototype had a 0.98 F1 Score or 98% accuracy in detecting high heating. Thus, the prototype successfully detected high heating in appliances with a 98% detection accuracy, thereby substantiating the first objective of the study. When comparing the computed F1 Score of the device in this current study with the previously developed ODET sensor by Carvajal *et al.* [30], which achieved an F1 Score of 0.67 or 67% detection accuracy, it becomes evident that the prototype in this present study excels in terms of both precision and recall, particularly in its capacity to classify high-heating situations. This comparison unequivocally points to the better detection accuracy of the device developed in this study.

Two hot bath tests were conducted to assess the accuracy of the LM35 temperature sensor. Upon comparing the results as in Table 8, the first hot bath test revealed an F1 score that fell short of the required accuracy for the sensor. Subsequently, a second hot bath test was performed, adjusting the temperature value to be 5 °C lower than the actual temperature. This adjustment resulted in an accurate outcome [30], justifying the study's objective that the LM35 temperature sensor must achieve more than a 95% accuracy value.

Table 7. Precision, recall, specificity, and F1 score of trials per temperature level in the second hot bath test

Temperature Level (°C)	Precision	Recall	Specificity	F1 Score
80	1.0	1.0	0	1.0
90	1.0	1.0	0	1.0
100	1.0	1.0	0	1.0
110	1.0	1.0	0	1.0
120	1.0	1.0	0	1.0
130	1.0	1.0	0	1.0
140	1.0	1.0	0	1.0
150	1.0	0.75	0	0.86
Average	1.0	0.97	0	0.98

Table 8. First hot bath test and second hot bath test results

	First Hot Bath Test	Second Hot Bath Test
Average Error (%)	0.74	1.13
Average Precision	1.0	1.0
Average Recall	0.68	0.97
Average Specificity	0	0
Average F1 Score	0.80	0.98

The functionality test results affirm that the prototype effectively performed its intended functions on the electric fan, obviating the need for further testing. Meeting the study's objectives, including a 95% accuracy rate and less than a 5% error, the prototype demonstrated a 98% accuracy, with percent errors of 0.74% and 1.13% in detecting high heat through F1 Score Analysis and the first and second hot bath tests, respectively. The auto-off mechanism, a key functionality, was successfully implemented as validated by three functionality tests. The prototype surpasses previous research by Singh *et al.* [26] and Chin *et al.* [27] with its expanded temperature range, enhancing monitoring capabilities for appliances with higher thresholds and improving temperature control and fire prevention. In comparison to Carvajal *et al.*'s [30] ODET sensor with a 67% accuracy, this prototype excels in precision and recall, achieving a 98% detection accuracy, signifying a significant advancement in high-heating event detection with potential applications for enhanced safety measures and monitoring systems. These findings highlight the current device's exceptional detection accuracy, representing a significant advancement in high-heating event detection with potential implications for enhancing safety measures and monitoring systems in relevant contexts.

5. LIMITATIONS AND FUTURE RESEARCH DIRECTIONS

This section addresses essential considerations in the development of the Arduino-based high heat detector temperature control prototype, encompassing programming, risks associated with high heat in diverse appliances, and future recommendations. Comprehensive discussions on these aspects aim to guide future improvements, ensuring the prototype's robustness and efficacy. The elucidation of these considerations provides a foundation for refining the prototype's functionality and reliability in subsequent research endeavors.

Based on the validation of the design, the expert suggested that it would be better to implement an SMS or mobile notification system that notifies homeowners and the nearest fire station in times when homeowners are outside the household in the event of high heating. This would prompt actions to prevent fire accidents. The second suggestion was to make the code reusable so that it can handle different device thresholds indicating that the researchers must have a library where they can input threshold values without modifying the code. The third suggestion was to improve the stability of temperature readings. Lastly, the expert recommended making the prototype portable.

Further research can be carried out to investigate the risks and conditions associated with high heat in various appliances. This additional investigation can provide in-depth recommendations regarding specific threshold levels for different appliances. In the present study, the current temperature threshold for the electric fan prototype is set at 100 °C. However, to ensure accurate detection of high heating incidents, the temperature value should be adjusted to 95 °C, as a 5 °C lower temperature reading is required. It is crucial to gather more data to establish a comprehensive and detailed list of high heating thresholds for different appliances.

Additional investigation on the risks and conditions of high heating of various appliances can be conducted to provide extensive recommendations on the threshold levels of specific appliances. In this study, the current temperature threshold for the subject appliance, an electric fan, is 100 °C but to achieve accurate results in detecting high heating situations, it must be coded to 95 °C since adjusting the temperature value of

100 °C must be 5 °C lower than the actual temperature. Beyond this, more data must be acquired to create a more comprehensive list of high heating thresholds. The study can be further improved by developing a prototype focusing on various appliances, not exclusively electric fans, and focusing on other aspects that contribute to fire incidents, not solely high heating.

The study focused solely on the development phase of the prototype and did not encompass the actual creation of a marketable product or involve mass production. As a result, the research procedure did not incorporate the final four steps of the R&D. These steps, namely: Prototype Revision, Usage Testing, Prototype Specification, and Mass Production, were not implemented in this study due to time constraints. However, the researchers recommended that future studies should include the mass production step to effectively implement the device and mitigate fire incidents in households in the Philippines. Future researchers need to consider the mass production step to successfully introduce the device to a wider market.

6. CONCLUSION

The developed Arduino-based high heat detector temperature control prototype successfully passed the comprehensive evaluation form, adapted from the Faculty of Mechanical Engineering at Universiti Teknologi MARA (UiTM). It demonstrated effectiveness and suitability across various factors, including performance, functionality, quality, manufacturing aspects, maintainability, health safety, risk issues, innovation, commercialization, and aesthetical values. The prototype addressed and rectified issues through revisions, ensuring proper functionality. Meeting all the criteria in the evaluation form signifies the prototype's acceptability and capability to perform its intended functions. This successful evaluation underscores the quality, safety, and effectiveness of the prototype, essential elements in the product development process.

The prototype showcased its effectiveness in detecting temperature changes, specifically in scenarios where appliances generate high heat. This implies that the prototype possesses the capability to accurately detect temperature variations across a wide range of threshold levels, including both low and high values. The prototype's demonstrated ability to detect temperature changes effectively indicates its adaptability and reliability in monitoring different appliances with varying heat generation capacities. By showcasing accurate detection capabilities at various threshold levels, the prototype proves its versatility and potential to be utilized in diverse settings where precise temperature monitoring is essential for preventing high-heat incidents and ensuring the safety of appliances and households.

The evaluation of the developed prototype during the second hot bath test indicates its effectiveness in alerting homeowners through high precision, recall, specificity, and F1-score parameters. With precision ensuring accurate detection, recall capturing and identifying actual high-heat incidents, specificity correctly classifying normal conditions, and the F1-score providing an overall measure, the prototype has demonstrated proficiency in alarming homeowners. These positive results contribute to enhanced safety and prevention of potential fire accidents by promptly notifying users of high-heat incidents, validating the effectiveness of the developed prototype's alarm system.

The Arduino-based high heat detector temperature control prototype has demonstrated its effectiveness in carrying out its intended functionalities. The prototype was able to activate an alarm and initiate the shutdown of the selected appliance when the control temperature reached the threshold level, ensuring the prevention of potential high heat incidents. Additionally, the prototype successfully maintained the operation of the appliance when the temperature remained within safe limits. The incorporation of an auto-off mechanism upon high heat detection further reinforces the prototype's ability to respond promptly to hazardous situations. The positive outcomes observed in the functionality tests confirm that the prototype performs as intended, highlighting its effectiveness in detecting and controlling high-heat incidents reliably and efficiently.

As electrical appliances are one of the leading causes of fire in the Philippines, it is essential to develop a device that could help mitigate this problem. The developed Arduino-based high heat detector temperature control prototype can turn off an electric fan once it detects high heating and prevents household fires. The prototype may serve as a basis for developing enhanced and more effective high heat detectors that could be utilized in other household appliances, further reducing the occurrence of fire accidents.

ACKNOWLEDGEMENTS

The authors extend their heartfelt gratitude to Sir Jas Felicisimo A. Cane, Ma'am Ruby Cajilla, Engineer Edsil Basadre, Ma'am Rachel Anne Pajal, and the anonymous reviewers and editors of IJRA for their technical assistance in this research. The authors would also like to extend their gratitude to their fellow researchers, Mr. Geo Guasa, Mr. Yoda Wyeth De Luna, and Mr. Alvin Mark Alemaño, for extending their

helping hands and contributing to the success of this research. Additionally, the primary author of this manuscript would like to recognize and convey her appreciation to Mr. Clyde Jake Jabao, Ms. Zyles Lacre, and Ms. Nikesha Allysson Radaza for their consistent moral support throughout the creation and revisions of this paper. The authors would also like to express their gratitude to Liceo de Cagayan University – Main Campus Senior High School for the financial assistance in this research.



REFERENCES

- [1] Philippine Statistics Authority, "Causes of Fire Incidence by Region: 2018 to 2021," *TABLE 17.8*, 2022. [Online]. Available: https://psa.gov.ph/system/files/psy/2022_T17_8.csv. [Accessed: March 21, 2024].
- [2] Y. B. Kurata, A. K. S. Ong, Y. T. Prasetyo, R. M. Dizon, S. F. Persada, and R. Nadlifatin, "Determining factors affecting perceived effectiveness among Filipinos for fire prevention preparedness in the national capital region, Philippines: integrating protection motivation theory and extended theory of planned behavior," *International Journal of Disaster Risk Reduction*, vol. 85, p. 103497, Feb. 2023, doi: 10.1016/j.ijdr.2022.103497.
- [3] M. M. Alam *et al.*, "An energy and leakage current monitoring system for abnormality detection in electrical appliances," *Scientific Reports*, vol. 12, no. 1, p. 18520, Nov. 2022, doi: 10.1038/s41598-022-22508-2.
- [4] C. C. Paglinawan, M. L. C. Bacabac, and T. J. D. Garcia, "Electrical fault detection and analysis Arduino-based preventive device for household appliances," in *2022 IEEE Region 10 Symposium (TENSYP)*, Jul. 2022, pp. 1–6. doi: 10.1109/TENSYP54529.2022.9864485.
- [5] M. Paulino and L. M. Paulino, "Causes of household fires in rural areas: An exploratory research," *Asian Journal of Community Services*, vol. 2, no. 5, pp. 389–394, May 2023, doi: 10.55927/ajcs.v2i5.4036.
- [6] K. Occeno, "Electrical post fire as cause of fire incidents in Region VI, Philippines," *JPAIR Multidisciplinary Research*, vol. 24, no. 1, pp. 111–121, Mar. 2016, doi: 10.7719/jpair.v24i1.382.
- [7] American Society for Testing Materials International, "Standard guide for heated system surface conditions that produce contact burn injuries," 2020. [Online]. Available: <https://www.astm.org/c1055-20.html>. [Accessed: Apr. 23, 2023].
- [8] Microtronics Technologies, "Microcontroller based overheat detector using temperature sensor with buzzer indication," *Microtronics Technologies – Projects Of 8051, Arduino, Raspberry Pi*. Available: <https://www.projectsof8051.com/microcontroller-based-overheat-detector-using-temperature-sensor-with-buzzer-indication/>. [Accessed: April 23, 2023].
- [9] A. A. Almubarak, "The effects of heat on electronic components," *International Journal of Engineering Research and Applications*, vol. 07, no. 05, pp. 52–57, Jun. 2017, doi: 10.9790/9622-0705055257.
- [10] Akitsu and Mitani, "Potential fire hazard and photochemical tests of azobenzene of several lightning sources," *Edelweiss Chemical Science Journal*, vol. 3, pp. 6–7, 2020.
- [11] B. Liao, A. A. Maznev, K. A. Nelson, and G. Chen, "Photo-excited charge carriers suppress sub-terahertz phonon mode in silicon at room temperature," *Nature Communications*, vol. 7, no. 1, Oct. 2016, doi: 10.1038/ncomms13174.
- [12] A. Hussain, M. Hammad, K. Hafeez, and T. Zainab, "Programming a microcontroller," *International Journal of Computer Applications*, vol. 155, no. 5, pp. 21–26, Dec. 2016, doi: 10.5120/ijca2016912310.
- [13] CircuitSchools Staff, "What is Arduino, how it works and what you can do with Arduino," *Circuit Schools*. Available: <https://www.circuitschools.com/what-is-arduino-how-it-works-and-what-you-can-do-with-arduino/>. [Accessed: March 18, 2023].
- [14] L. Louis, "Working principle of Arduino and using it as a tool for study and research," *International Journal of Control, Automation, Communication and Systems*, vol. 1, no. 2, pp. 21–29, Apr. 2016, doi: 10.5121/ijcacs.2016.1203.
- [15] C. Liu, W. Ren, B. Zhang, and C. Lv, "The application of soil temperature measurement by LM35 temperature sensors," in *Proceedings of 2011 International Conference on Electronic & Mechanical Engineering and Information Technology*, Aug. 2011, vol. 4, pp. 1825–1828. doi: 10.1109/EMEIT.2011.6023459.
- [16] N. A. Junizan, A. A. Razak, B. Balakrishnan, and W. A. F. W. Othman, "Design and implementation of automatic room temperature controlled fan using Arduino Uno and LM35 heat sensor," *International Journal of Engineering Creativity and Innovation (IJEI)*, Jan. 2019.
- [17] R. Sheldon, "What are sensors and how do they work?" Available: <https://www.techtarget.com/whatis/definition/sensor>. [Accessed: March 20, 2023].
- [18] A. Bhalajai, "Arduino based digital temperature sensor," *Project Hub*, 2020. Available: <https://create.arduino.cc/projecthub/abishek-bhalajai/arduino-based-digitaltemperature-sensor-76e16c>. [Accessed: March 22, 2023].
- [19] A. O. Ayeni, "Design of low cost, RGB Arduino-based temperature monitor using LM35 sensor," *IJISRT (International Journal of Innovative Science and Research Technology)*.
- [20] M. Ramos, "Characterization of LM35 Sensor for Temperature Sensing of Concrete," in *Lecture Notes in Engineering and Computer Science*, 2017, vol. 2228, pp. 760–764.
- [21] "General purpose relays," *OMRON*. Available: <https://www.ia.omron.com/support/guide/36/introduction.html>. [Accessed: March 18, 2023].
- [22] V. Gurevich, *Electric relays*. CRC Press, 2018. doi: 10.1201/9781315221168.
- [23] J. W. Simatupang, L. M. Andrian, W. Zhuang, and H. Prasetyo, "A prototype of an Arduino-based protection system to overcome voltage fluctuations," in *2019 International Conference on Computer, Control, Informatics and its Applications (IC3INA)*, Oct. 2019, pp. 172–176. doi: 10.1109/IC3INA48034.2019.8949584.
- [24] W. M. Galita and W. M. Valerio, "Motion activated, temperature controlled (MATC) electric fan," *Journal of Engineering and Applied Sciences Technology*, pp. 1–5, Mar. 2022, doi: 10.47363/JEAST/2022(4)135.
- [25] J. S. Jahlool, "Design and Simulation of Automatic Temperature Control and Alert System Based PIC16F887," *APTIKOM Journal on Computer Science and Information Technologies*, vol. 2, no. 2, pp. 77–85, Jul. 2017, doi: 10.11591/APTIKOM.JCSIT.108.
- [26] D. Singh, K. Singh, R. Manhas, R. Kaushal, and H. Channi, "Modeling and simulation of machine overheat detection with alert system," Nov. 2017, doi: 10.13140/RG.2.2.17755.26409.
- [27] V. S. Chin, P. G. Teo, M. Z. Mohd Ibrahim, W. A. F. Wajdi Othman, and A. A. A. Wahab, "Development of low-cost temperature sensing fan using mapping method on Arduino Uno and LM35 temperature sensor," *Technical Journal of Electrical Electronic Engineering and Technology (TJEET)*, 2019.
- [28] X. Zhou and T. Schoepf, "Detection and formation process of overheated electrical joints due to faulty connections," in *26th*



- International Conference on Electrical Contacts (ICEC 2012)*, 2012, pp. 288–295. doi: 10.1049/cp.2012.0663.
- [29] C.-J. Lin and H.-C. Lin, "Overheat prevention device," Patent No. US 7,967,447 B2, 2011
- [30] K. L. S. Carvajal, I. G. Estrada, and E. G. Leal, "ODET: An Arduino-based overheat detector for household appliances," *Computer and Software Technology, and Robotics (CSR)*, May 2022.
- [31] Official Gazette of the Republic of the Philippines, *Republic Act No. 9514: An act establishing a comprehensive fire code of the Philippines, repealing Presidential Decree no. 1185 and for other purposes*. 2008. [Online]. Available: <https://www.officialgazette.gov.ph/2008/12/19/republic-act-no-9514/>. [Accessed: March 21, 2023].
- [32] "Annex 9: Model guidance for the storage and transport of time- and temperature-sensitive pharmaceutical products," in *Supplement 10: Checking the accuracy of temperature control and monitoring devices - Technical supplement to WHO Technical Report Series No. 961*, World Health Organization, 2011. [Online]. Available: <https://www.who.int/publications/m/item/Annex-9-i-trs-961>. [Accessed: March 18, 2023].
- [33] Sugiyono, *Educational research methods: quantitative, qualitative and R & D approaches (in Indonesia: Metode penelitian pendidikan : Pendekatan kuantitatif, kualitatif dan R & D)*. Bandung: Alfabeta, 2008.
- [34] University of Iowa, "Imaging the Universe," *Physics and Astronomy University of Iowa*. Available: <https://itu.physics.uiowa.edu/>. [Accessed: April 28, 2023].
- [35] K. M. Ting, "Confusion matrix," in *Encyclopedia of Machine Learning and Data Mining*, Boston, MA, MA: Springer US, 2017, pp. 260–260. doi: 10.1007/978-1-4899-7687-1_50.
- [36] "False positive and false negative: definition and examples," *Statistics How To*. Available: <https://www.statisticshowto.com/false-positive-definition-and-examples/>. [Accessed: April 28, 2023].
- [37] "Classification: True vs. false and positive vs. negative," *Google for Developers*. Available: <https://developers.google.com/machine-learning/crash-course/classification/true-false-positive-negative>. [Accessed: April 12, 2023].
- [38] S. Mishra, "Baffling concept of true positive and true negative," *Towards Data Science, 2021*. Available: <https://towardsdatascience.com/baffling-concept-of-true-positive-and-true-negative-bffbc340f107>. [Accessed: April 17, 2023].
- [39] "WAC 246-215-04220: Accuracy—Temperature measuring devices, food (FDA Food Code 4-203.11)," *Washington State Legislature*. Available: <https://app.leg.wa.gov/wac/default.aspx?cite=246-215-04220>. [Accessed: April 28, 2023].
- [40] "LM35 precision centigrade temperature sensors," Texas Instruments, 1999. [Online]. Available: <https://www.ti.com/lit/ds/symlink/lm35.pdf>. [Accessed: March 7, 2023].

BIOGRAPHIES OF AUTHORS





Rhoda Mae L. Casinillo    is a Science, Technology, Engineering, and Mathematics (STEM) strand student of Liceo de Cagayan University, Cagayan de Oro City, Philippines. This research was conducted in partial fulfillment of the requirements for the Senior High School Department Science, Technology, Engineering, and Mathematics (STEM) strand. She is currently taking up a Bachelor of Science in Electronics Engineering at Mindanao State University – Iligan Institute of Technology. She can be contacted at rhodamae.casinillo@g.msuiit.edu.ph or rmcasinillo95142@liceo.edu.ph.





Allecia Leona A. So    is a Science, Technology, Engineering, and Mathematics (STEM) strand student of Liceo de Cagayan University, Cagayan de Oro City, Philippines. This research was conducted in partial fulfillment of the requirements for the Senior High School Department Science, Technology, Engineering, and Mathematics (STEM) strand. She can be contacted at also71774@liceo.edu.ph.







Maezel V. Mandaya    is a Science, Technology, Engineering, and Mathematics (STEM) strand student of Liceo de Cagayan University, Cagayan de Oro City, Philippines. This research was conducted in partial fulfillment of the requirements for the Senior High School Department Science, Technology, Engineering, and Mathematics (STEM) strand. She can be contacted at mmandaya65319@liceo.edu.ph.







Sonny Adrian J. Dabalos     is a Science, Technology, Engineering, and Mathematics (STEM) strand student of Liceo de Cagayan University, Cagayan de Oro City, Philippines. This research was conducted in partial fulfillment of the requirements for the Senior High School Department Science, Technology, Engineering, and Mathematics (STEM) strand. He can be contacted at [sadabalos98467@liceo.edu.ph](mailto:sadalos98467@liceo.edu.ph).



Mark Ceasar S. Enriquez     is a Science, Technology, Engineering, and Mathematics (STEM) strand student of Liceo de Cagayan University, Cagayan de Oro City, Philippines. This research was conducted in partial fulfillment of the requirements for the Senior High School Department Science, Technology, Engineering, and Mathematics (STEM) strand. He can be contacted at mcenriquez45294@liceo.edu.ph.



Jas Felicisimo A. Cane     has been a Science and Mathematics Teacher for five years in both Junior and Senior High School, he holds a Bachelor of Science in Secondary Education majoring in Physics, and a master's degree in science education majoring in Physics at Mindanao State University – Iligan Institute of Technology. A Licensed Professional Teacher. He has mentored STEM students in developing robotics and automation projects and won several awards in the Science Investigatory Projects Competition in the Philippines. His research interests include Robotics, STEM Education, Science Instrumentation, Physics Education, and Educational Pedagogies. He can be contacted at jcane@liceo.edu.ph or jasfelicis.cane@g.msuiit.edu.ph.